

# The End of Percussion Maintenance

Mark Jermeay, Ingersoll Rand Fluid Technologies

**A new motor technology for diaphragm pumps combats three confounding pump motor issues: freezing, stalling, and poor energy efficiency.**

**N**amed for a technique commonly used on failing pumps, “percussion maintenance” – where a technician beats on the pump’s stalled motor with a hammer or rubber mallet – often indicates motor deficiencies in his diaphragm pump. Though it is impossible for the maintenance department to predict when a pump will stall, such maintenance techniques are often the result of poor motor design.

Diaphragm pump performance is critical to process plant operations. However, many facilities view diaphragm pumps as commodity items and, as such, continue to invest in underperforming platforms. With the purchase price of diaphragm pumps comprising as little as five percent of the overall cost of ownership, operating the wrong pump can lead to significant financial losses.

There can be several reasons for substandard performance, including application demands, fluid composition, pump specifications, compressed air contamination, air leakage,

debris and general wear and tear. However, three of the biggest complaints – freezing, stalling and poor energy efficiency – are often due to insufficient motor design.

## Problem: Freezing

Freezing is a chronic problem that causes the motor to seize up and fail in many applications. Freezing occurs as compressed air expands and creates a severe decrease in pressure. As the air returns to atmospheric pressure, it turns extremely cold, freezing any moisture in the air supply.

This cold air has been measured as low as negative 30-deg, causing ice particles to accumulate and clog the motor area and muffler. The ice buildup stalls the pump, and it will remain down until ambient air or another device can melt the ice. Many facilities develop workarounds, such as implementing space heaters, hot water taps and other thawing mechanisms. However, these efforts tie up the maintenance team and

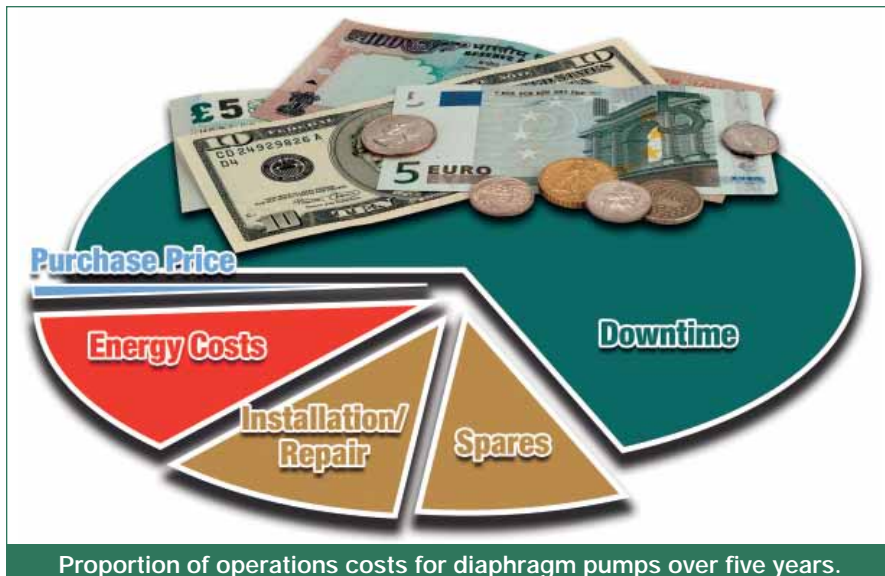

require additional resources.

The most effective solution is to utilize a pump that exhausts air from the chamber as quickly as possible. Diaphragm pumps should not allow exhaust to go through critical motor components, such as the spool valves. When this happens, the exhaust port becomes blocked with ice and causes the motor to slow down or completely stop.

Instead, the most effective motor designs on the market today eliminate pump ice-up by protecting the major air valve from cold, wet exhaust air. Internal components that divert the exhaust air away from the major air valve and into an expansion chamber can dramatically increase pump reliability and remove the need for ice preventive devices.

### Problem: Stalling

Though diaphragm pumps often claim to be “unstallable,” many of these do a poor job of managing the pressure acting on their air valves. The best way to tell whether a pump will stall is to look at its air valve design.

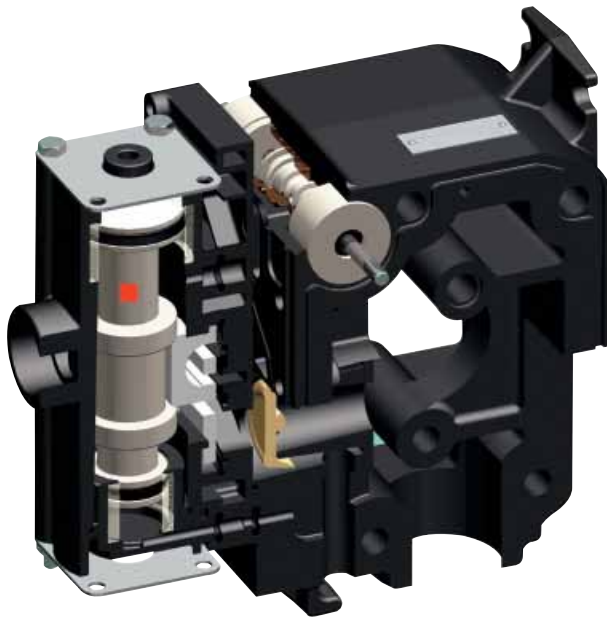

The red dot is placed on the unbalanced major air valve. An unbalanced valve design eliminates valve centering and pump stall-out-even under low air inlet pressures.

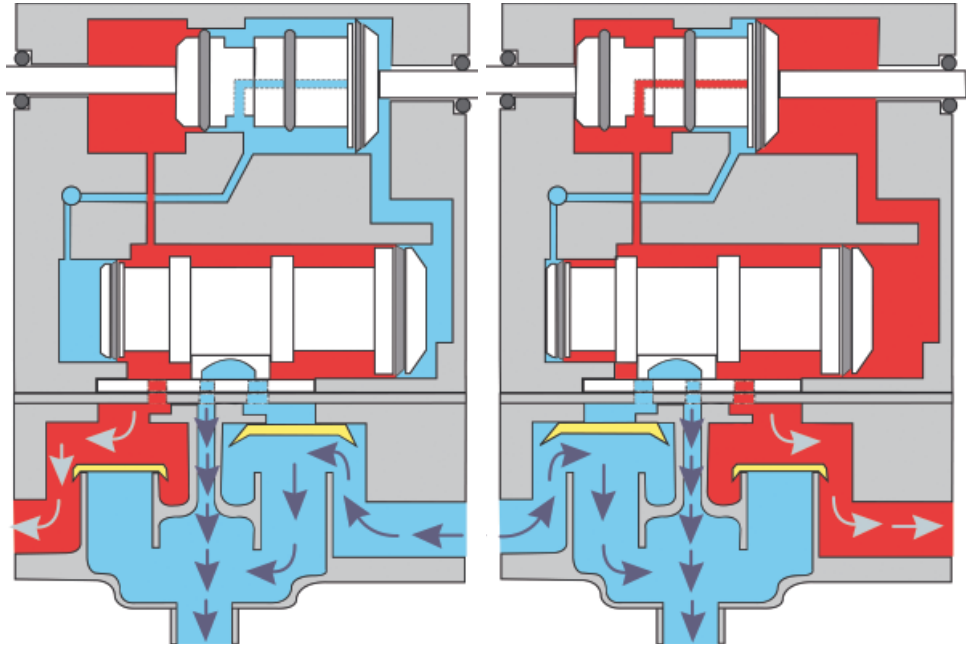

These diagrams show the cold (blue) and warm (red) air movements as the diaphragm moves back and forth. Note how the cold, wet intake air is always diverted from the air valves.

Conventional valves feature a “balanced” design in which the valve is too evenly weighted. Air valves using this design often generate poor shift signals and, over time, the valve centers with an equal pressure differential on both sides. These pressures cancel each other out and the air valve does not shift, causing the pump to stall. Other pumps are susceptible to stalling during restart. When the fluid valves are shut off, pressure in the pump equalizes and can make it difficult to begin shifting the air valve again.

Diaphragm pumps can eliminate air valve centering by utilizing an “unbalanced” valve design. This air valve design features a large diameter on one end of the valve and a small diameter on the opposite end, creating the optimal pressure differential. Since the valves are always biased toward one side, they do not center out and stall the pump, even under low air inlet pressures. Unbalanced valves reduce production loss and downtime by providing better shift signals and delivering faster trip-over with more flow.

### Problem: Poor Energy Efficiency

Bad motor design also creates poor energy efficiency. In diaphragm pumps this means underperforming seals and valves. Many manufacturers utilize an O-ring configuration on spools to prevent air leakage, but this design often wears and creates a poor seal, creating air blow-by and reducing efficiency.

Blow-by is also caused by a metal-to-metal lapped-fit valve design. This model utilizes a spool with a slightly smaller diameter than the bore it is in, creating a gap that allows compressed air to escape. Air leaks past the valve during operation in a dead-head condition, exhausting to the atmosphere and significantly decreasing energy efficiency.

Buyers should be cautious when seeking to increase efficiency. There can be more than 40 percent difference among competing brands of energy efficient diaphragm pumps.

Diaphragm pump motors can utilize a positive seal on the valve spool created by U-cups to maximize energy efficiency. These prevent air leakage by providing a positive seal as the valve shifts. Additionally, seal points should be made of solid

materials (ceramic components are often best) where applicable to ensure longer life. Special materials, such as over-molded sleeves, should be utilized to increase lubricity and reduce or eliminate wear in the valving mechanisms.

Carbon and glass are often inserted into moldings to create a stronger housing for the valve. However, these abrasive materials can migrate to the surface and rub against the seals, decreasing seal life. An alternative construction features over-molded, pure materials with no abrasive fillers that creates strong housings and good surfaces. These sorts of features can save plants hundreds of dollars each year per pump.

*Freezing, stalling and poor energy efficiency of diaphragm pumps is often due to insufficient motor design.*

### The Future of Motor Technology

The main concern in years past was flow rate, but that has begun to change over the last five years. As plants become increasingly energy conscious, more customers balance pump productivity and air consumption better. Manufacturers continue to optimize motor designs to get the most production out of the least air volume.

Diaphragm pumps will continue to emerge as viable continuous-duty pumps, particularly in the process industry. New materials, technology and better construction have eliminated the perception that these pumps were not as effective as their counterparts. Innovative designs and materials have dramatically increased pump reliability, efficiency and durability and provided additional chemical compatibility and abrasion resistance.

P & S

*Mark Jermeay is a marketing manager for Ingersoll Rand Fluid Technologies, One ARO Center, PO Box 151, Bryan, OH 43506-0151, 419-636-4242, [www.irtools.com/aro](http://www.irtools.com/aro).*

## EccentricPumps™

A New Revolution in Hose Pump Technology™



## Handling the toughest jobs!

- 50% More Flow per Rotation
- One Compression per Revolution
- Fewest Compressions per 100 Gallons Pumped
- Multiple Hose Sizes per Pump Housing
- Hose Technology "Made in America"

### Eccentric Pumps LLC

P.O. Box 190159, Atlanta, GA 31119  
Tel: 404.816.4760 Fax: 404.816.4759  
Web: [www.eccentricpumps.com](http://www.eccentricpumps.com)

circle 127 on card or go to [psfreeinfo.com](http://psfreeinfo.com)